

# DOOSAN INFRACORE INDUSTRIAL ENGINE

## D24



Intermittent rating kW(HP) / rpm	Max. torque N.m(kg.m) / rpm	EPA/CARB Compliance	EU Compliance
37 (49) / 2600	175 (17.8) / 1800	Tier4 F	Stage3B
46 (61) / 2600	225 (22.9) / 1800		
49 (66) / 2600	245 (25.0) / 1800		
54 (74) / 2600	280 (28.6) / 1800		

### © MECHANICAL SYSTEM

o Engine Model	D24
o Engine Type	In-line 4 cycle Diesel, water cooled, Turbo-intercooler
o Combustion type	Direct injection
o Cylinder Type	Linerless
o Number of cylinders	4
o Bore x stroke	90 x 94 mm
o Displacement	2.392 lit.
o Compression ratio	17.0 : 1
o Firing order	1-3-4-2
o Dry weight	233 kg (w/o starter, alternator, aftertreatment)
o Dimension (LxWxH)	840.4 x 553.8 x 774.7 mm (with DOC)
o Rotation	Counter clockwise viewed from Flywheel
o Fly wheel housing	SAE NO.4M(SAE J617)
o Fly wheel	Clutch 10"(SAE J620)
o Number of teeth (Flywheel)	104

### © FUEL SYSTEM

o Injection pump	DELPHI DFP 4.4
o Governor	Controlled by ECU
o Feed pump	N/A
o Injection nozzle	Multi hole type
o Fuel filter	Full flow, cartridge type
o Used fuel	EN590

### © LUBRICATION SYSTEM

o Lub. Method	Fully forced pressure feed type
o Oil pump	Gear type driven by crankshaft
o Oil filter	Full flow, cartridge type
o Oil pan capacity	High level 8.6 liters Low level 4.5 liters
o Angularity limit	35 deg all around
o Lub. Oil	10W30 CJ-4 (Refer to Operation Manual)
o Maximum oil temp	135°C at main oil gallery
o Lub oil pressure	Idle Speed : Min 100 kPa

### © ENGINEERING DATA

---

o Water flow	105 liters/min @2,600 rpm (74HP)
o Heat rejection	
-to coolant	9.5 kcal/sec @2,600 rpm (74HP)
-to CAC	2.0 kcal/sec @2,600 rpm (74HP)
o Air flow	4,603 liter/min @2,600 rpm (74HP)
o Exhaust gas temp.	750 °C ↓ @2,600 rpm
o Max. permissible restrictions	
-Intake system	2.16 kPa clean filter 6.23 kPa dirty filter
-Exhaust system	15 kPa max.

### © VALVE SYSTEM

---

o Type	Over head valve
o Number of valve	Intake 2, exhaust 2 per cylinder
o Valve lashes	Intake 0.4mm
(@ cold)	Exhaust 0.45mm

### © COOLING SYSTEM

---

o Cooling method	Fresh water forced circulation
o Water capacity	Approx. 4 lit
(engine only)	
o Water pump	Centrifugal type driven by belt
o Thermostat	Wax – pellet type
	Opening temp. 82°C
	Full open temp. 97°C
o Cooling fan	-
o Water Temperature	110°C (max.)

### © ELECTRICAL SYSTEM

---

o Battery Charging	12V x 90A
Alternator	
o Voltage regulator	Built-in type IC regulator
o Starting motor	12V x 2.7kW
o Battery Voltage	12V
o Battery Capacity	100 Ah, 950CCA (recommended)
o Starting Aid	Glow plug

### 37KW(49HP)

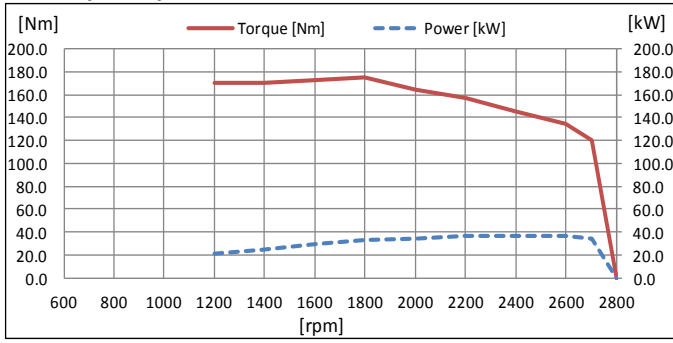

speed	Power			Torque	
	kW	PS	HP	Nm	kgm
1200	21.4	29.0	28.6	170.0	17.3
1400	24.9	33.9	33.4	170.0	17.3
1600	28.9	39.3	38.8	172.5	17.6
1800	33.0	44.8	44.2	175.0	17.8
2000	34.6	47.0	46.3	165.0	16.8
2200	36.2	49.2	48.5	157.0	16.0
2400	36.4	49.5	48.9	145.0	14.8
2600	36.6	49.7	49.0	134.3	13.7
2700	34.2	46.4	45.8	120.8	12.3
2800	0.0	0.0	0.0	0	0.0
3000	0.0	0.0	0.0	0	0.0

### 46KW(61HP)

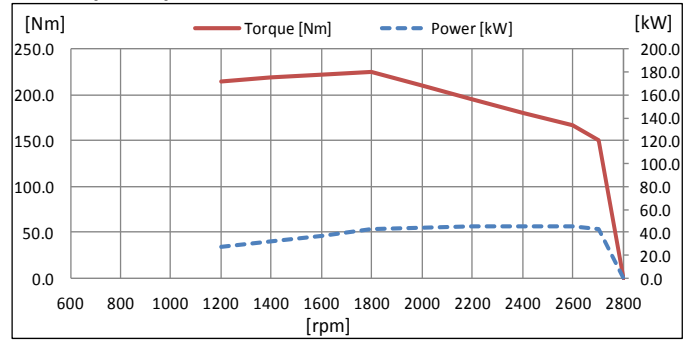

speed	Power			Torque	
	kW	PS	HP	Nm	kgm
1200	27.0	36.7	36.2	215.0	21.9
1400	32.3	43.9	43.3	220.0	22.4
1600	37.3	50.7	50.0	222.5	22.7
1800	42.4	57.7	56.9	225.0	22.9
2000	44.0	59.8	59.0	210.0	21.4
2200	44.9	61.1	60.2	195.0	19.9
2400	45.2	61.5	60.7	180.0	18.4
2600	45.5	61.9	61.0	167.1	17.0
2700	42.5	57.8	57.0	150.4	15.3
2800	0.0	0.0	0.0	0	0.0
3000	0.0	0.0	0.0	0	0.0

### 49KW(66HP)

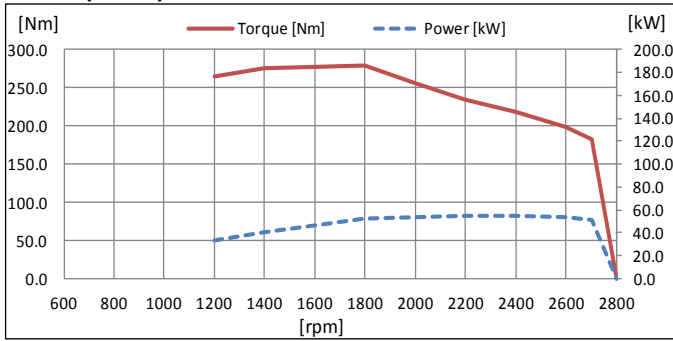

speed	Power			Torque	
	kW	PS	HP	Nm	kgm
1200	29.5	40.2	39.6	235.0	24.0
1400	35.2	47.8	47.2	240.0	24.5
1600	40.6	55.2	54.5	242.5	24.7
1800	46.2	62.8	61.9	245.0	25.0
2000	47.8	64.9	64.0	228.0	23.2
2200	48.4	65.8	64.9	210.0	21.4
2400	49.0	66.6	65.7	195.0	19.9
2600	49.2	66.9	66.0	180.7	18.4
2700	46.0	62.6	61.7	162.8	16.6
2800	0.0	0.0	0.0	0	0.0
3000	0.0	0.0	0.0	0	0.0

### 54KW(74HP)

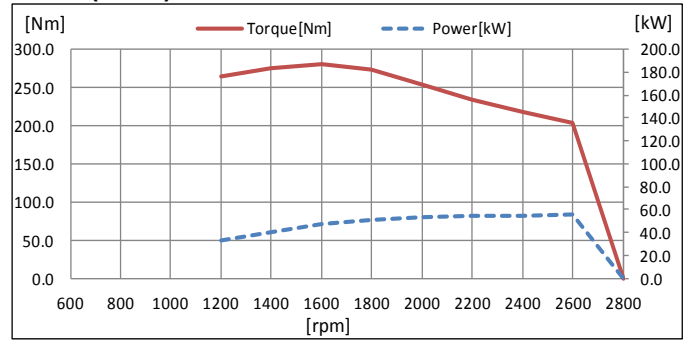

speed	Power			Torque	
	kW	PS	HP	Nm	kgm
1200	33.3	45.3	44.7	265.0	27.0
1400	40.3	54.8	54.1	275.0	28.0
1600	46.5	63.2	62.4	277.5	28.3
1800	52.8	71.8	70.8	280.0	28.6
2000	53.6	72.9	71.9	256.0	26.1
2200	54.1	73.6	72.6	235.0	24.0
2400	54.8	74.5	73.5	218.0	22.2
2600	55.4	75.3	74.3	203.5	20.8
2700	51.6	70.2	69.2	182.5	18.6
2800	0.0	0.0	0.0	0	0.0
3000	0.0	0.0	0.0	0	0.0

o Dimension (LxWxH) 840.4 x 553.8 x 774.7 mm (with DOC)

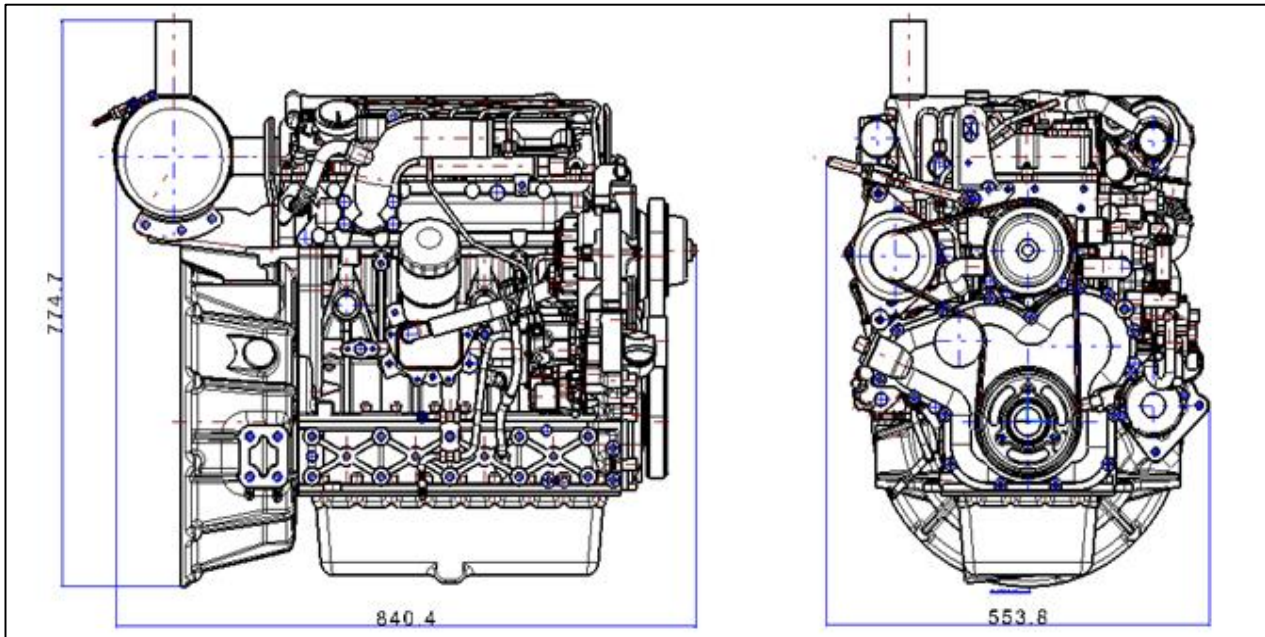

#### ◆ CONVERSION TABLE

in. = mm x 0.0394	lb/ft = N.m x 0.737
PS = kW x 1.3596	U.S. gal = lit. x 0.264
psi = kg/cm <sup>2</sup> x 14.22	kW = 0.2388 kcal/s
in <sup>3</sup> = lit. x 61.02	lb/PS.h = g/kW.h x 0.00162
hp = PS x 0.98635	cfm = m <sup>3</sup> /min x 35.336
lb = kg x 2.20462	

Revised : 6th, September, 2016

※ Specifications are subject to change without prior notice